

ATTACHMENT TOOLS

ATTACHMENT TOOLS



WELCOME...



SPECIALISTS IN LANDSCAPE MAINTENANCE

GreenTec is a Danish company specialized in machines for the maintenance of green areas. Our products are based on almost 30 years of experience in the field.

We offer a large selection of hydraulic attachment tools for hedge trimming, verge mowing, windbreak maintenance, fence and guardrail trimming, ditch cleaning, etc. The tools are easily mounted on tractors, excavators and loaders through our Scorpion boom arms or Multi Carrier HXF series.

All machines are developed in a simple and functional design at our facilities in Denmark. We guarantee high quality and reliable products.

CONTENTS

HEDGEROW MAINTENANCE

Rotary Mulcher RM 2324
 Quadsaw LRS 14026
 Quadsaw LRS 16027
 Quadsaw LRS 20028
 Quadsaw LRS 24029
 Twinsaw LRS 2002 & 240210
 Cutterbar HX 170 - 27011

HEDGE CUTTING

Cutterbar HL 152 - 24214
 Rotary Hedge Cutter RC 102 - 162....15
 Cutterbar HS 172 - 24216

VERGE MOWING

Flail Mower FR 92 - 16220
 Barrier Mower RI 60 & 8022
 Rotary Crusher GT 135 & 15523
 Grass Cutterbar S 165 - 24024
 Leaf Blower LG25

VARIOUS TOOLS

Rotary Ditch Cleaner GR 7028
 Weed Clearing Brush BR 70 & 9029

 Multi Carrier HXF30
 Boom Mower Scorpion32
 Specifications34



HEDGEROW MAINTENANCE

PERFECT CUTTING QUALITY

ROTARY MULCHER RM 232

MADE IN
DENMARK





↑
m
2.3
↓

cm
< 4

km/h
4

kg
310

2
years
WARRANTY



STRONG ARGUMENTS

- Perfect cutting quality
- High capacity
- No disposal of cut-off material
- Minimal wear and maintenance
- Many mounting options

The Rotary Mulcher RM 232 provides enormous capacity and perfect performance. In one operation, branches are cut and instantly mulched.

The Rotary Mulcher RM 232 has 4 rotors with 6 blades on each rotor. The free-hanging blades in the bottom cut the branches while the blades in the top pulverize them. In case of an overload, the blades will rotate backward. Branches up to 4 cm are cut and crushed. The small twigs slowly sprinkle from the bottom of the machine to the ground and the decomposing process begins. The RM 232 has a working width of 2.3 m and is specially designed for windbreak and roadside maintenance in cutting intervals of up to three years. The working speed is up to 4 km/h depending upon the density of the hedge. Very large capacity and no clean up required.

ROTARY MULCHER RM	232
Working width (m)	2.3
Weight (kg)	310
Max. branch thickness (cm)	Ø4
Oil flow (l/min)	50

QUADSAW LRS 1402



↑
m
↓
1.4

cm
< 10

km/h
5

kg
48

2
years
WARRANTY



STRONG ARGUMENTS

- Perfect cutting quality
- Power Drive Transmission
- Saw blades with Widia teeth
- Low weight
- Flexible mounting brackets

The Quadsaw LRS 1402 is a small yet powerful quadsaw with four saw blades and a working width of 1.4 m.

The quadsaw is useful in multiple sectors, such as farming, municipal and private. The Quadsaw LRS 1402 is known for its perfect and clean cut of both thin and thick branches (up to 10 cm). It can adventurously be fitted on compact reach arms or the Multi Carrier HXF 2302 and HXF 2802.

QUADSAW LRS	1402
Working width (m)	1.4
Weight (kg)	48
Max. branch thickness (cm)	Ø10
Oil flow (l/min)	25



↑
↓
m
1.6

cm
< 12

km/h
5

kg
110

2
years
WARRANTY



STRONG ARGUMENTS

- Perfect cutting quality
- High forward speed
- Low power requirements
- Power Drive Transmission
- Saw blades with Widia teeth

The QuadSaw LRS 1602 differs from the larger models with its very low noise level, which make it suitable for use in both the agricultural and municipal segments. Each of the blades has a branch driver mounted. It ensures that branches are directed into the blades. Thick or thin branches are both cut smoothly.

The QuadSaw LRS 1602 is produced in high-strength steel and only weighs 110 kg.

QUADSAW LRS	1602
Working width (m)	1.6
Weight (kg)	110
Max. branch thickness (cm)	Ø12
Oil flow (l/min)	40

QUADSAW LRS 2002



↑
m
↓
2.0

cm
< 16

km/h
5

kg
198

2
years
WARRANTY



STRONG ARGUMENTS

- Extreme performance
- High efficiency
- Saw blades with Widia teeth
- Power Drive Transmission
- Perfect cutting quality

The Quadsaw LRS 2002 has an unmatched capacity with its four saw blades and low maintenance costs. The quadsaw is produced in high-strength steel with a low weight of 198 kg. All branches receive a smooth and clean cut.

QUADSAW LRS	2002
Working width (m)	2.0
Weight (kg)	198
Max. branch thickness (cm)	Ø16
Oil flow (l/min)	50



↑
m
2.4
↓

cm
< 21

km/h
5

kg
239

2
years
WARRANTY

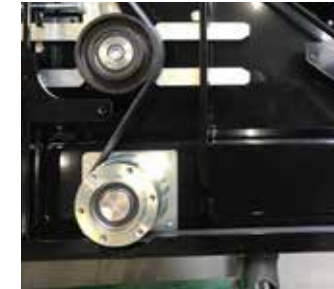

YouTube

STRONG ARGUMENTS

- Perfect cutting quality
- Low power requirements
- Long life
- Power Drive Transmission
- Saw blades with Widia teeth

The QuadSaw LRS 2402 is the second largest saw in the series and has an enormous power and capacity. Branches up to 21 cm are cleanly cut - experienced drivers can manage branches up to 40 cm.

The QuadSaw LRS 2402 can be fitted to reach arms, excavators, loaders and the Multi Carrier HXF 3302 - as long as they have the lifting capacity and at least 50 l/min oil available.

QUADSAW LRS	2402
Working width (m)	2.4
Weight (kg)	239
Max. branch thickness (cm)	Ø21
Oil flow (l/min)	50

TWINSAW LRS 2002 & 2402



↑
m
4.0-4.8

↘
cm
< 21

km/h
5

kg
510-600

2
years
WARRANTY



STRONG ARGUMENTS

- Extreme performance
- High efficiency
- Saw blades with Widia teeth
- Power Drive Transmission
- Perfect cutting quality

GreenTec presents the world's largest saw with working widths of 4.0 and 4.8 m for municipal and farming use. The saw is fitted to large diggers, excavators and loaders. It goes without saying that the capacity is enormous.

TWINSAW LRS	2002	2402
Working width (m)	4.0	4.8
Weight (kg)	510	600
Max. branch thickness (cm)	16	21
Oil flow (l/min)	2 x 50	2 x 50



- m
1.7-2.7
- cm
< 11
- km/h
2
- kg
180-260

2
years
WARRANTY



STRONG ARGUMENTS

- **Hardox steel trimmer bars**
- **Extreme lifespan**
- **Cutting frequency: 60 double strokes/min**
- **Soft Turn technology**
- **Hydraulic oil flow divider**

A very strong and effective cutterbar used for cutting back trees and bushes. It has a clean cut and does not leave split or frayed branches. The cutterbar can be attached to reach mowers, excavators and the Multi Carrier HXF 3302.

CUTTERBAR HX	170	230	270
Working width (m)	1.7	2.3	2.7
Weight (kg)	180	220	260
Max. branch thickness (cm)	11	11	11
Oil flow (l/min)	50	50	50



BOOMER

HYBRID ARM SYSTEM









HEDGE TRIMMING
HIGH PERFORMANCE AND EFFICIENCY

CUTTERBAR HL 152 - 242



- 
 1.5-2.4 m
- 
 < 4 cm
- 
 2 km/h
- 
 60-72 kg

2

years

WARRANTY



STRONG ARGUMENTS

- **Fast Frequency Cut System, 200-400 cuts/min.**
- **Fingers with ball ends**
- **Fast replaceable blade**
- **Perfect cutting quality**

The four models in the HL series are powerful hedge trimmers for the regular maintenance of hedges, both in the municipal, residential and agricultural sectors. The special fluted blades leave a smooth cut on the branches.

Branches up to 4 cm in thickness and small twigs are perfectly cut.

CUTTERBAR HL	152	182	212	242
Working width (m)	1.5	1.8	2.1	2.4
Weight (kg)	60	64	68	72
Max. branch thickness (cm)	4	4	4	4
Oil flow (l/min)	20	25	25	25

ROTARY HEDGE CUTTER RC 102 - 162



↑ m
1.0-1.6

cm
< 4

km/h
2.5

kg
100-200

2
years
WARRANTY

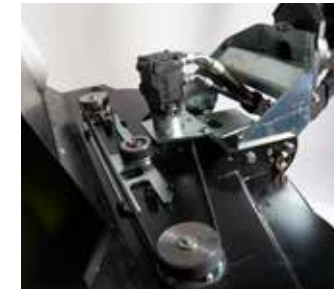

STRONG ARGUMENTS

- Reduction of diseases in the hedge
- No disposal of cut-off material
- Minimal wear and maintenance
- Enclosed cutter housing
- Low noise level

The Rotary Hedge Cutter RC is a professional attachment tool designed specifically for hedge cutting and developed for the discerning customer with a focus on: Cutting Performance, Efficiency, Output and Working Environment.

The Rotary Hedge Cutter RC 102, 132 and 162 perform three workflows in one operation. The RC series cuts the hedge with a clean cut, the cut-off material is shredded and disposed by decay on the ground.

ROTARY HEDGE CUTTER RC	102	132	162
Working width (m)	1.0	1.3	1.6
Weight (kg)	100	150	200
Max. branch thickness (cm)	2	3	4
Oil flow (l/min)	25	40	50

CUTTERBAR HS 172 - 242

MADE IN DENMARK





↑
m
1.7-2.4

cm
< 6

km/h
5

kg
120-145

2
years
WARRANTY



STRONG ARGUMENTS

- Perfect cutting quality
- Gentle and smooth cutter bar
- Double-sharpened blades
- Quick replacement of blades
- HD planetary gearbox w/cast iron engine

The HS series is a very versatile machine as it can be used for both hedge trimming and windbreak maintenance.

The Cutterbar HS 172 – 242 can cut branches up to 6 cm (2.36”) in thickness. Even small twigs receive a completely smooth cut. By combining the finger bars with the specially sharpened blades, you achieve a high performance and an impeccable finish.

CUTTERBAR HS	172	212	242
Working width (m)	1.7	2.1	2.4
Weight (kg)	120	132	145
Max. branch thickness (cm)	6	6	6
Oil flow (l/min)	40	50	50



GREENTEC R162



VERGE MOWING

EFFORTLESS MAINTENANCE

FLAIL MOWER FR 92 - 162

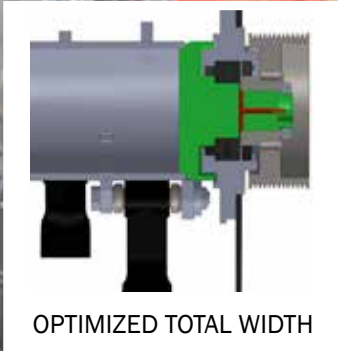

OPTIMIZED TOTAL WIDTH

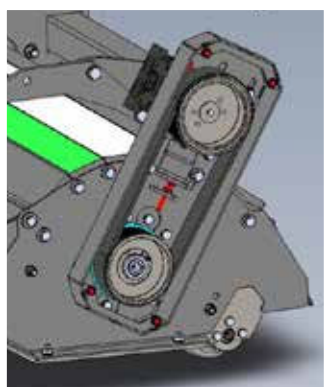

POWER BELT DRIVE

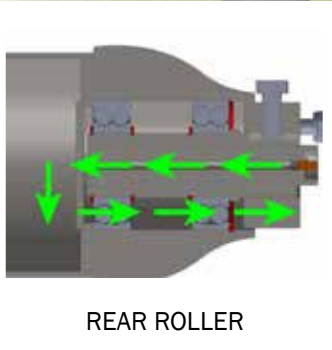

REAR ROLLER



OPTIMIZED SHAPE OF FLAILS

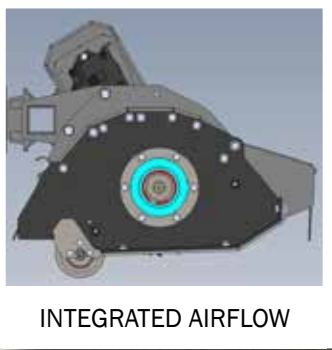

INTEGRATED AIRFLOW



DOUBLE SPIRAL ROTOR





-  m
0.9-1.6
-  cm
< 4
-  km/h
5-7
-  kg
138-360



2
 years
WARRANTY

STRONG ARGUMENTS

- **Integrated Airflow increases the capacity**
- **Integrated rotor bearings**
- **Power Belt drive**
- **Strenx 700 steel construction**
- **Double spiral rotor with uniform flow**

The Integrated Airflow system is one of the main features of the FR series. The space between the rotor and the shield is purposely designed to increase the air velocity so the cut-off material exits the mower as quickly as possible. It creates a natural vacuum that sucks the grass into the mower. This increases the capacity of the flail head and reduces the power requirement. The main bearings are integrated in the rotor shaft which reduces the total width of the flail head. The flails are adapted to the rotor to stop breakage and damage from happening. The machines are manufactured in Strenx 700 high strength steel which is one of the most durable steel types in the world.

FLAIL MOWER FR	92	112	122	162
Working width (m)	0.9	1.1	1.2	1.6
Weight (kg)	138	144	320	360
Max. branch thickness (cm)	4	4	4	4
Oil flow (l/min)	40	40	85	85

BARRIER MOWER RI 60 & 80



STRONG ARGUMENTS

- Anti-scalping protection disc
- Good ground following capability
- Adjustable spiral springs
- Rubber protection around the disc
- Two blades for uniform cutting results

The Barrier Mower RI 60 & 80 is the ideal tool to cut under fence wires, horse pen fences, crash barriers or to cut close around trees in orchards. Below the spring-suspended free-hanging plate, there are two strong updraft blades that mow the grass.

BARRIER MOWER RI	60	80
Working width (m)	0.6	0.8
Weight (kg)	45	60
Support plate	Std.	Std.
Min./Alt. oil flow (l/min)	40/25	40/25

ROTARY CRUSHER GT 135 & 155



- m

1.35-1.55
- cm

< 7
- km/h

5
- kg

410-460

2
 years
WARRANTY



STRONG ARGUMENTS

- Perfect for shrubbery
- Double deck
- Low maintenance costs
- Pendant suspension
- 2 cutting systems

The Rotary Crusher GT 135 & 155 is specially developed for use in extreme conditions with many stones and stumps. It comes with two cutting systems: chains or blades. The chains are used for mowing grass and shrubs in stony conditions. The blades are used for hedge cutting and grass mowing in normal conditions. Both systems are very robust.

ROTARY CRUSHER GT	135	155
Working width (m)	1.35	1.55
Weight (kg)	410	460
Max. branch thickness (cm)	7	7
Min./Alt. oil flow (l/min)	85/110	85/110

GRASS CUTTERBAR S 165 - 240



↔ m
1.65-2.4

km/h
3

kg
70-102

2 years
WARRANTY



STRONG ARGUMENTS

- Hydraulic driven
- Delivered for right or left working
- Bidux blade system
- Used in areas that are difficult to reach
- Durable
- Eco-friendly mowing - unharmed to insects and plants

The Grass Cutterbar S 165 - 240 is used for cutting grass in inaccessible areas where a fine spread and chop of the cut-off material is not a demand.

GRASS CUTTERBAR S	165	190	210	240
Working width (m)	1.65	1.9	2.1	2.4
Weight (kg)	70	82	92	102
Oil flow (l/min)	34	34	34	34

LEAF BLOWER LG



STRONG ARGUMENTS

- High-pressure blower made of aluminum
- Very high airflow
- Uses the hydraulics of the tractor
40 l/min (10.6 gpm)
- External mounting or integrated with
the Scorpion boom mowers

The Leaf Blower LG is a high-pressure blower that is hydraulically driven through the tractor's hydraulics.

It is used in conjunction with a verge mower for removing the debris left on the road. It can also be mounted on a boom arm and remove snow from solar panels.



HYBRID



GREENTEC

SCORPION



VARIOUS TOOLS
MAINTAIN ROADS AND DITCHES

ROTARY DITCH CLEANER GR 70



← m →
0.65

km/h
1

kg
220



STRONG ARGUMENTS

- Efficient cleaning of ditches
- Continuous duty motor
- Skid shoe
- Adjustable front hood
- Hydraulic driven

The Rotary Ditch Cleaner GR 70 is a highly efficient machine for cleaning of smaller ditches and streams. The sludge and weeds are effectively removed and thrown up on the cliff.

The ditch cleaner is hydraulic driven and can be fitted to a boom arm.

ROTARY DITCH CLEANER GR	70
Working width (m)	0.65
Weight (kg)	220
Min. oil flow (l/min)	70

WEED CLEARING BRUSH BR 70 & 90



- ↔
m
- 0.7-0.9
- ⊙
km/h
- 1
- ⚖
kg
- 55-230



STRONG ARGUMENTS

- **Powerful and effective**
- **Hard steel brushes**
- **Hydraulic driven**
- **Durable**

2
years

WARRANTY

The Weed Clearing Brush BR 70 & 90 effectively cleans sidewalks, gutters, bicycle paths, courtyards, anywhere where there are tiles, asphalt or paving stones. The strong steel brushes easily remove dirt, sludge and weeds.

WEED CLEARING BRUSH BR	70	90
Working width (m)	0.7	0.9
Weight (kg)	55	230
Directional and pressure relief valves	-	Standard
Oil flow (l/min)	25	50

MULTI CARRIER HXF



MOUNTING OPTIONS - HXF OR SCORPION...

All our tools are hydraulic powered which means that the hydraulic oil must be supplied to make the bars, flails and blades run. GreenTec offers two mounting options for our tools: The Multi Carrier HXF series or the Boom Mower Scorpion series. Both solutions are described in detail on the following pages. Alternatively, the tools can be mounted on various excavators and other manufacturers of reach arms. We also offer a large selection of adapters and brackets for mounting. Further information at www.greentec.eu

HXF 2302



6
Tools

25
l/min

AHS 45°

2
years
WARRANTY

The Multi Carrier HXF 2302 can easily be mounted on smaller vehicles, such as skid steer loaders and compact tractors with a minimum weight of 1,200 kg (2,646 lb).

A wide variety of tools can be attached to the Multi Carrier HXF 2302 for hedge trimming and windbreak maintenance as well as fence mowing and cleaning of sidewalks. A hydraulic and mechanical quick release system makes it easy to swap between tools.

The hydraulic system of the vehicle must be able to deliver oil of 25 l/min (6.6 gpm). The cutting head can be adjusted from a vertical to horizontal position through a spindle.

HXF 2802 & 2802 TELE



11
Tools

25-40
l/min

AHS 45°

2
years
WARRANTY

The Multi Carrier HXF 2802 can be installed on front end loaders and large skid steer loaders in a few minutes.

A large selection of tools for hedge cutting and hedgerow trimming is available. It is also possible to mount a barrier mower or weed brush on the Multi Carrier HXF 2802.

The arm has a hydraulic break-back system with Auto Reset which also acts as a cushion to the saw.

HXF 3302 & 3302 TELE



13
Tools

40-50
l/min

AHS 45°

2
years
WARRANTY

The Multi Carrier HXF 3302 is the largest model in the HXF series and is mainly mounted on telehandlers, large front end loaders and backhoes.

A large selection of tools for hedge trimming and shelter-belt maintenance can be fitted to the Multi Carrier HXF frame, such as the quadsaws and cutterbars.

The HXF 3302 is mounted in the loading bracket of the vehicle. The mounting process only requires a few minutes of your time.

The arm has an automatic hydraulic break-back system with pre-pressure which optimizes the workflow and prevents overload from happening.

MODEL	2302
Reach (center vehicle/end Quadsaw) (m)	1.8
Transport width (m)	1.3
Std. oil flow (l/min)	25
Alt. oil flow (l/min)	-
Weight without bracket (kg)	110

	2802	2802 T
Reach (center vehicle/end Quadsaw) (m)	2.2	1.4 - 2.2
Transport width (m)	2.0	2.4
Std. oil flow (l/min)	40	40
Alt. oil flow (l/min)	25	25
Weight without bracket (kg)	150	175

	3302	3302 T
Reach (center vehicle/end Quadsaw) (m)	2.5	1.6 - 2.5
Transport width (m)	2.2	2.5
Std. oil flow (l/min)	50	50
Alt. oil flow (l/min)	40	40
Weight without bracket (kg)	200	230

BOOM MOWER SCORPION



 **MADE IN DENMARK**



SCORPION 4 S & PLUS



The Scorpion 4 series consists of compact reach mowers intended for smaller tractors, implement carrier, skid steer loaders and the like. The models are available in horizontal working widths of 3.3 and 4.3 m (10'10" and 14'1").

As a standard, the Danfoss hydraulic valve is controlled by the proportional mini joystick and Hybrid Arm System.

The Scorpion 4 series is built in a modular system and available in different versions. A wide range of attachment tools makes the Scorpion a popular choice throughout the entire year.

MODEL	330-4 S	430-4 S	330-4 PLUS	430-4 PLUS
Horizontal reach (m)	3.3	4.3	3.3	4.3
Vertical reach (m)	3.1	4.1	3.1	4.1
Transport width (m)	1.8	2.2	1.8	2.2
Hydraulic system	52 l/min @ 210 bar		52 l/min @ 210 bar	
Min. size of vehicle (kg)	1,500	2,000	1,650	2,200
Weight (kg)	570	590	610	630

SCORPION 6 S & 6 PLUS



The Scorpion 6 series is available in four models and is designed for medium-sized tractors with a weight of at least 4,000 kg (8,818 lb).

The patented 4-point mounting system connects the tractor and the boom mower and gives 100% stability. It is also easy to mount.

The Hybrid Arm System provides great flexibility and increases the work capacity and environment. The Danfoss hydraulic system ensures high reliability and output. Furthermore, the joystick is easy to operate.

	530-6 S	630-6 S	530-6 PLUS	630-6 PLUS
Horizontal reach (m)	5.3	6.3	5.3	6.3
Vertical reach (m)	5.1	6.1	5.1	6.1
Transport width (m)	2.2	2.2	2.2	2.2
Hydraulic system	115 l/min @ 230 bar		125 l/min @ 315 bar	
Min. size of vehicle (kg)	4,000	5,000	4,000	5,000
Weight (kg)	1,235	1,270	1,370	1,395

SCORPION 8 S & 8 PLUS



The Scorpion 8 series represents the largest boom mowers in the Scorpion range. It consists of four models.

The Scorpion 8 series is suitable for large tractors with a weight of 7,000 kg (15,432 lb) and above.

All scorpion models are manufactured in Strenx 700 high strength steel. You truly see the greatness of the Strenx steel at the longer reaches as it reduces the weight while increasing the strength.

The boom mowers are easily fitted with a 4-point mounting system which is connected to the 3-point hitch of the tractor and two K80 ball hitches as well.

	730-8 S	830-8 S	730-8 PLUS	830-8 PLUS
Horizontal reach (m)	7.3	8.3	7.3	8.3
Vertical reach (m)	7.1	8.1	7.1	8.1
Transport width (m)	2.4	2.5	2.4	2.5
Hydraulic system	115 l/min @ 230 bar		125 l/min @ 315 bar	
Min. size of vehicle (kg)	7,000	8,000	7,000	8,000
Weight (kg)	1,475	1,505	1,600	1,630

TECHNICAL SPECIFICATIONS



	ROTARY MULCHER	QUADSAW				TWINSAW		CUTTERBAR		
ATTACHMENT TOOLS:	RM 232	LRS 1402	LRS 1602	LRS 2002	LRS 2402	LRS 2002	LRS 2402	HX 170	HX 230	HX 270
Working width (m)	2.3	1.4	1.6	2.0	2.4	4.0	4.8	1.7	2.3	2.7
Weight (kg)	310	48	110	198	239	510	600	180	220	260
Max. branch thickness (cm)	Ø4	Ø10	Ø12	Ø16	Ø21	Ø16	Ø21	Ø11	Ø11	Ø11
Max. working speed (km/h)	4	5	5	5	5	5	5	2	2	2
Min. oil flow (l/min./oil pressure)	50/180	25/190	40/190	50/180	50/180	2x50/180	2x50/180	50/190	50/190	50/190
Alt. oil flow (l/min./oil pressure)	-	-	-	85/150	85/150	1x100/180	1x100/180	-	-	-
MOUNTING OPTIONS:										
HXF	-	2302/2802	2802/3302	3302		-	-	3302		
SCORPION	6/8	4		6/8		-	-	6/8		

	ROTARY CRUSHER	BARRIER MOWER		GRASS CUTTERBAR				
ATTACHMENT TOOLS:	GT 135	GT 155	RI 60	RI 80	S 165	S 190	S 210	S 240
Working width (m)	1.35	1.55	0.6	0.8	1.65	1.9	2.1	2.4
Weight (kg)	410	460	45	60	70	82	92	102
Max. branch thickness (cm)	Ø7	Ø7	-	-	-	-	-	-
Max. working speed (km/h)	5	5	3	3	3	3	3	3
Min. oil flow (l/min./oil pressure)	85/280	85/280	40/190	40/190	34/180	34/180	34/180	34/180
Alt. oil flow (l/min./oil pressure)	110/300	110/300	25/190	25/190	-	-	-	-
MOUNTING OPTIONS:								
HXF/FOX	-	-	2302/2802/FOX		-	-	-	-
SCORPION	6/8	8 PLUS	-	-	4/6/8		6/8	

CUTTERBAR				ROTARY HEDGE CUTTER			CUTTERBAR			FLAIL MOWER			
HL 152	HL 182	HL 212	HL 242	RC 102	RC 132	RC 162	HS 172	HS 212	HS 242	FR 92	FR 112	FR 122	FR 162
1.5	1.8	2.1	2.4	1.0	1.3	1.6	1.7	2.1	2.4	0,9	1,1	1,2	1,6
60	64	68	72	100	150	200	120	132	145	138	144	320	360
Ø4	Ø4	Ø4	Ø4	Ø2	Ø3	Ø4	Ø6	Ø6	Ø6	Ø4	Ø4	Ø4	Ø4
2	2	2	2	2,5	2,5	2,5	5	5	5	5-7	5-7	5-7	5-7
20/190	25/190	25/190	25/190	25/190	40/190	50/180	40/190	50/190	50/190	40/210	40/210	85/230 85/315	85/230 85/315
32/190	40/190	40/190	40/190	-	-	-	-	-	-	-	-	-	-
2302/2802	2802/3302		-	2302/2802	2802/3302	3302	2802/3302	3302		-	-	-	-
4				6/8		6/8	4	6/8		4		6/8	

DITCH CLEANER	WEED CLEARING BRUSH		LEAF BLOWER
GR 70	BR 70	BR 90	LG
0.65	0.7	0.9	-
220	55	230	-
-	-	-	-
1	1	1	-
70/320	25/190	50/190	-
-	40/190	-	-
-	2302/2802	-	-
6/8	-	6/8	-

GreenTec offers the widest selection of tools for landscape maintenance.

View more on:
www.GreenTec.eu



OUR WARRANTY

GreenTec provides a 2-year warranty on all machines. See more on our website: www.greentec.eu



DEALER: